

WARING
COMMERCIAL



Blender MX 1500

WARING
COMMERCIAL

02.06.3811



Tampa secundária do copo

026425

WARING
COMMERCIAL

02.06.3813



Tampa principal do copo

026424

WARING
COMMERCIAL

02.06.3812



Jarra de policarbonato
503398

WARING
COMMERCIAL

02.06.2910



Proteção acústica SE-1000

502962

02.06.4462



Lâmina do copo

503397

02.06.4890



Oring da lâmina

024271

WARING
COMMERCIAL

02.06.4891

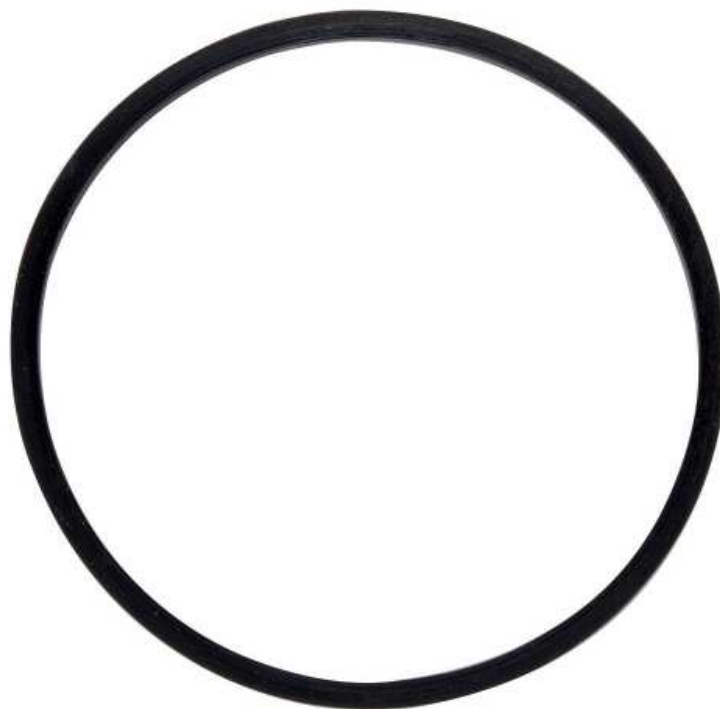

Gaxeta da porca de fixação da lâmina

024268

02.06.3824

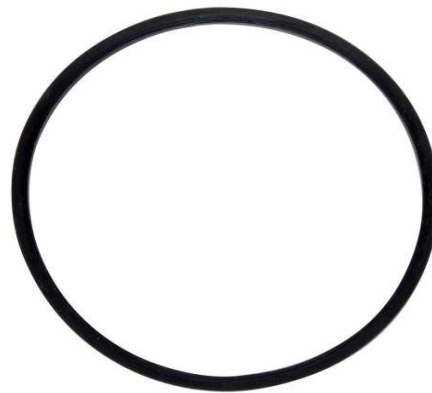

Kit Lâmina C/ gaxeta, oring e porca

030889

02.06.4461



Chave para retirar a lâmina

032761

WARING
COMMERCIAL

02.06.3826



Encaixe do motor

028538

02.06.3814



Apoio do copo na base

026443

02.06.4463

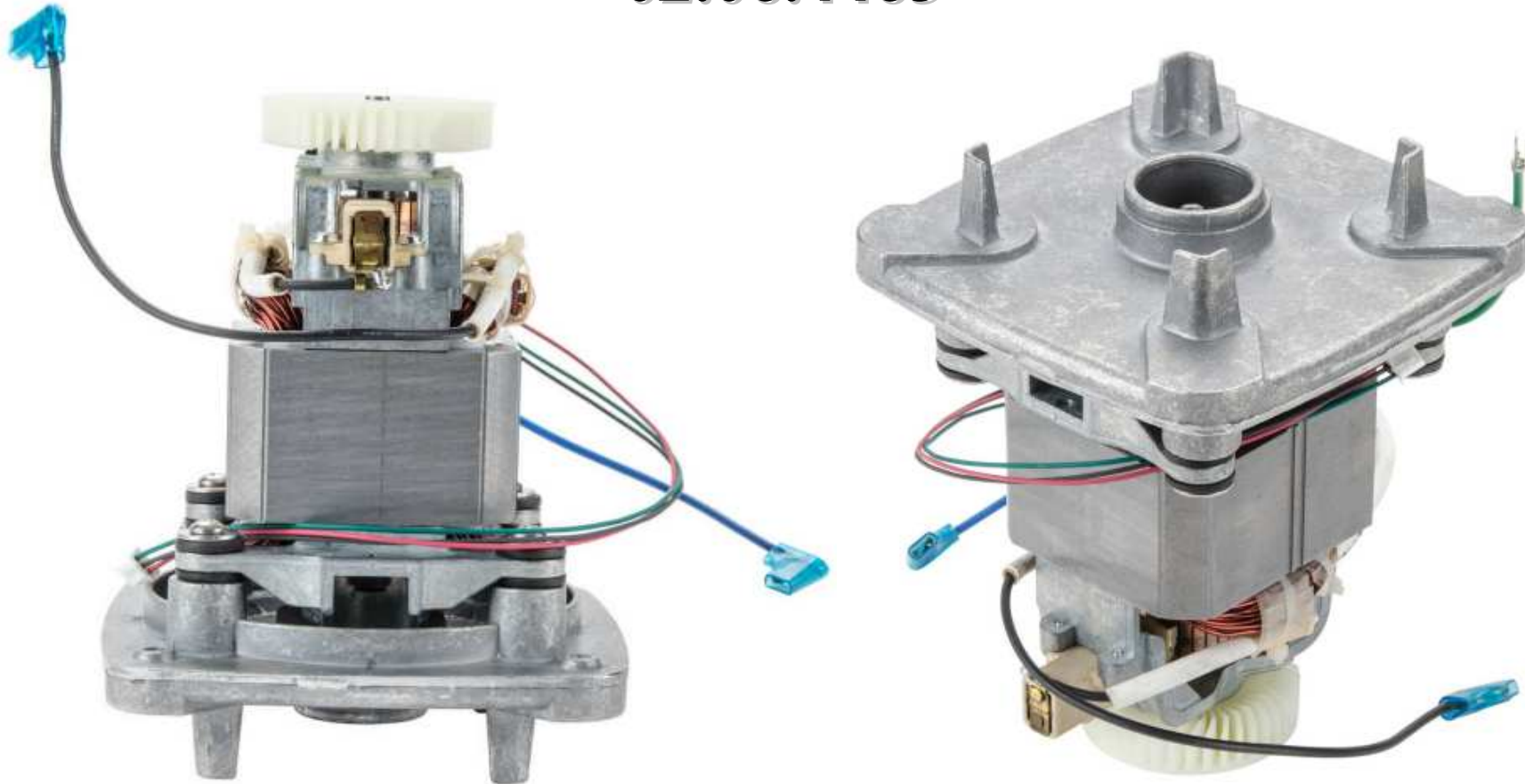

Motor 220V/60HZ – MX 1500

028824

02.06.3820



Junta de vedação do motor

026437

WARING
COMMERCIAL

02.06.3828



Espuma de proteção do motor

028541

02.06.4464



Painel Eletrônico 220V/60Hz – Mx 1500

029816

02.06.4886



Espuma de proteção acústica traseira

028248

02.06.4888



Espuma de proteção acústica esquerda

028247

02.06.4887



Espuma de proteção acústica dianteira

028249

02.06.4889



Espuma de proteção acústica direita

028542

02.06.4115



Ferramenta para retirar o encaixe do motor

503351



Diagrama eléctrico



Suporte técnico

Estevão Moraes (21)3147-1043

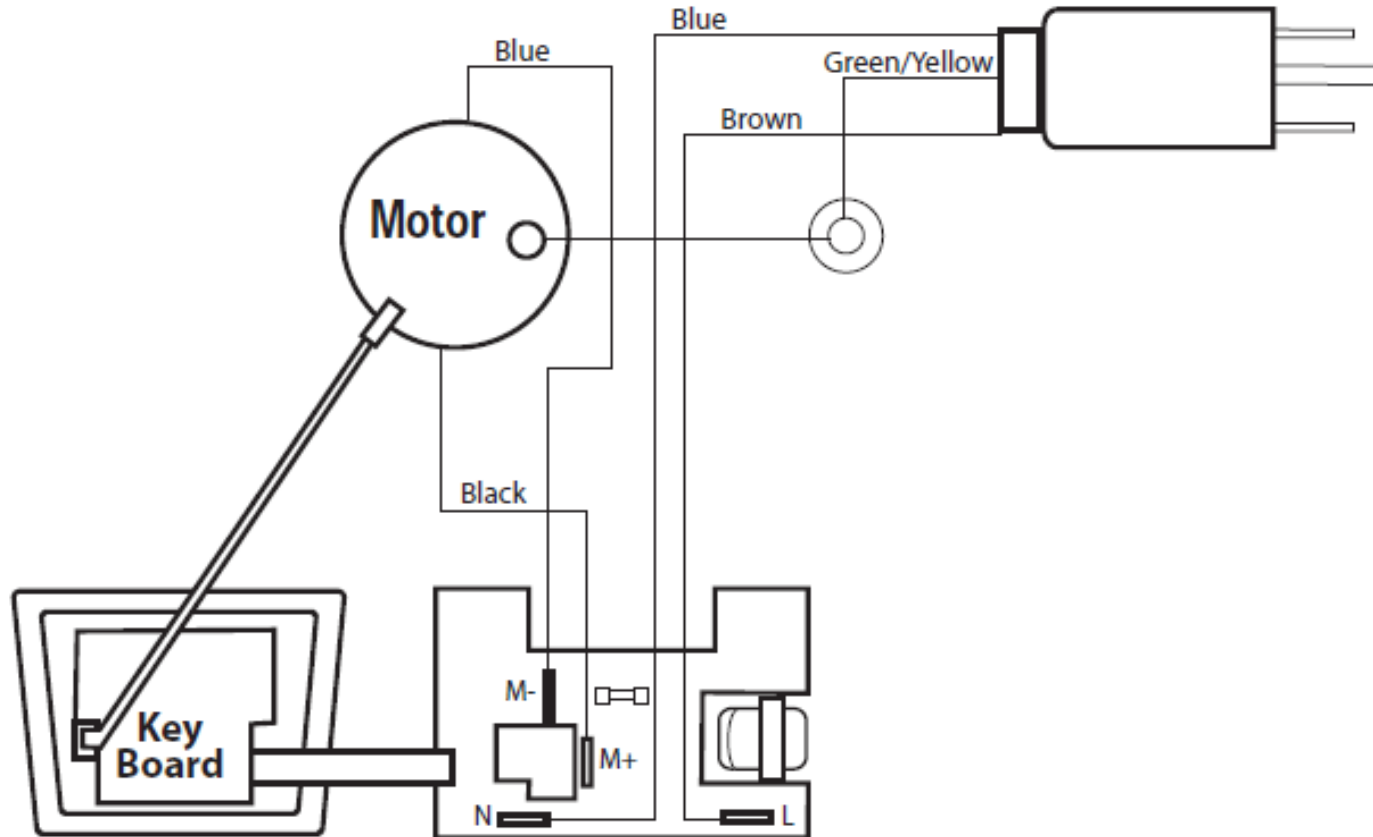
Adriano Belarmino (21)3147-1065

Marcelo Sarmiento (21)3147-1022

